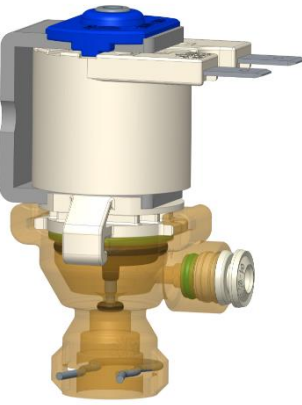
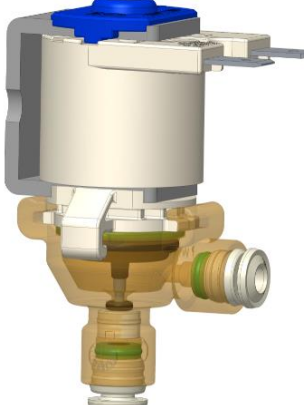

	TECHNICAL DATASHEET <i>SCHEMA TECNICA</i>	Cod.: V2
	FAMILY NAME: Steam Series V2 DN 1.5	Rev.: 01
	<i>FAMIGLIA:</i> <i>Serie Vapore V2 DN 1.5</i>	Data: 24/11/2021

		WORKING CHARACTERISTICS	
		Working pressure:	0 ÷ 18 bar
		Room temperature:	0 ÷ 60°C
		Fluid temperature:	0 ÷ 140°C
		Flow direction:	Unidirectional
		Nominal diameter:	DN 1.5
		Max sealing pressure:	25 bar
		Max back-pressure:	8 bar
		Elect.Pilot/Control:	Direct opening
		CARATTERISTICHE DI LAVORO	
		Pressione di esercizio:	0 ÷ 18 bar
		Temperatura ambiente:	0 ÷ 60°C
		Temperatura fluido:	0 ÷ 140°C
		Direzione fluido:	Unidirezionale
		Diametro di passaggio:	DN 1.5
		Max pressione di tenuta:	25 bar
		Max contropressione:	8 bar
		Elet.Pilota/Comando:	Apertura diretta

PHYSICAL CHARACTERISTICS		CARATTERISTICHE FISICHE	
Valve body:	PPSU	Corpo valvola:	PPSU
Diaphragm:	LSR/EPDM	Membrana:	LSR/EPDM
O-ring sealing	EPDM	o-ring tenuta	EPDM
Core:	Stainless steel	Nucleo:	Acciaio INOX
Spring:	Stainless steel	Molla:	Acciaio INOX
Assembly:	Bayonet	Assemblaggio:	Baionetta

INSTALLATION		INSTALLAZIONE	
The valve can be installed in any position without compromising the functions		La valvola può essere montata in qualsiasi posizione senza comprometterne il funzionamento	

APPLICATIONS		APPLICAZIONI	
Coffee machines Appliances Medical equipments Irons Water dispensers Wherever there is need for water control, even at high temperatures		Macchine per caffè Elettrodomestici Attrezzature medicali Ferri da stiro Distributori d'acqua Ovunque ci sia necessità di controllo dell'acqua, anche ad elevate temperature	

HYDRAULIC CONNECTIONS		CONNESSIONI IDRAULICHE	
Inlet:	Fork Push Fit Ø 4 mm	Inlet:	Forchetta Push Fit Ø 4 mm
Output:	Push Fit Ø 4 mm	Output:	Push Fit Ø 4 mm

ELECTRICAL CONNECTIONS		CONNESSIONI ELETTRICHE	
Connection	6,3 x 0,8 mm Male Faston	Connessione	Faston Maschio 6,3 x 0,8

SOLENOID RANGE		GAMMA SOLENOIDI	
See table attached		Vedi tabella in allegato	

MARKS AND CERTIFICATIONS		MARCHI ED APPROVAZIONI	
MOCA, IMQ-CSV		MOCA, IMQ-CSV	
CE, NSF(only materials)		CE, NSF(solo materiali)	



TECHNICAL DATASHEET

SCHEDA TECNICA

Cod.: V2

FAMILY NAME: Steam Series V2 DN 1.5

Rev.: 01

FAMIGLIA: Serie Vapore V2 DN 1.5

Data: 24/11/2021

SOLENOID TABLE

TABELLA SOLENOIDI

Associated Diameter	Progress code	Voltage	Frequency	Holding Power	InRush Power	Holding Current	InRush Current	cos Ø	Duty Cycle	Insulation class	Coil insulation class	Connections	Effective Approvals	Normally Close	Normally Open	Latching
Diametro Associato	Codice progressivo	Tensione	Frequenza	Potenza di mantenimento	Potenza di spunto	Corrente di mantenimento	Corrente di spunto	cos Ø	ED	Classe di isolamento	Classe isolamento bobina	Connessioni	Approvazioni Attive	Norm. Chiusa	Norm. Aperta	Bistabile
		(V)	(Hz)	(W) - (VA)	(W) - (VA)	(mA) (@ 20°C)	(mA) (@ 20°C)									
DN 1.5	1	24V DC	=	11.8 W	/	491 mA	/	/	3ON 5OFF	II	F	Faston	ENEC, GW	✓	/	x
	2	12V DC	=	16,8 W	/	1400 mA	/	/	3ON 5OFF	II	F	Faston	ENEC, GW	✓	/	x

Legenda (Legend)

NC: Normalmente Chiusa / **Normally Closed**

NA: Normalmente Aperta / **Normally Open**

NB: Bistabile / **Latching**

ED Funzionamento (**Duty Cycle**) = 3ON 5OFF

Possibili Approvazioni – **Potential Approvals**: ENEC, UL, GW (Glow Wire)

Faston: IP X0

Cavi (**wires**): IP 55

Classe isolamento (**Insulation class**): II

Classe isolamento bobina (**Coil insulation class**): F

Tipo faston (**Faston type**): 6,3 x 0,8 mm

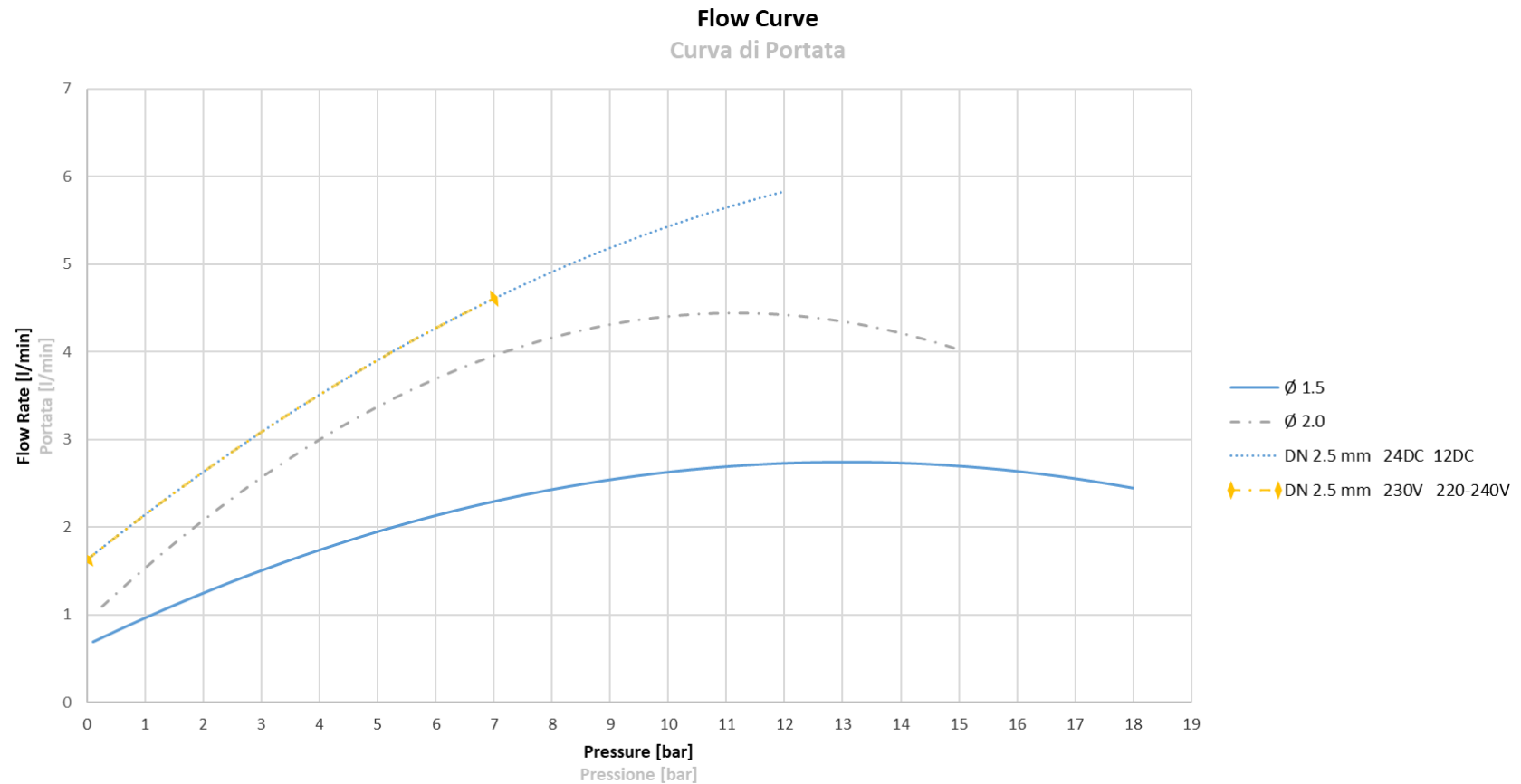
**TECHNICAL DATASHEET***SCHEDA TECNICA***Cod.:** V2**FAMILY NAME:** Steam Series V2 DN 1.5**Rev.:** 01*FAMIGLIA:* Serie Vapore V2 DN 1.5**Data:** 24/11/2021**FLOW RATE***CURVA DI PORTATA*



TECHNICAL DATASHEET *SCHEMA TECNICA*

FAMILY NAME: Steam Series V2 DN 1.5

FAMIGLIA: Serie Vapore V2 DN 1.5

Cod.: V2

Rev.: 01

Data: 24/11/2021

WORKING SCHEME

SCHEMA DI FUNZIONAMENTO

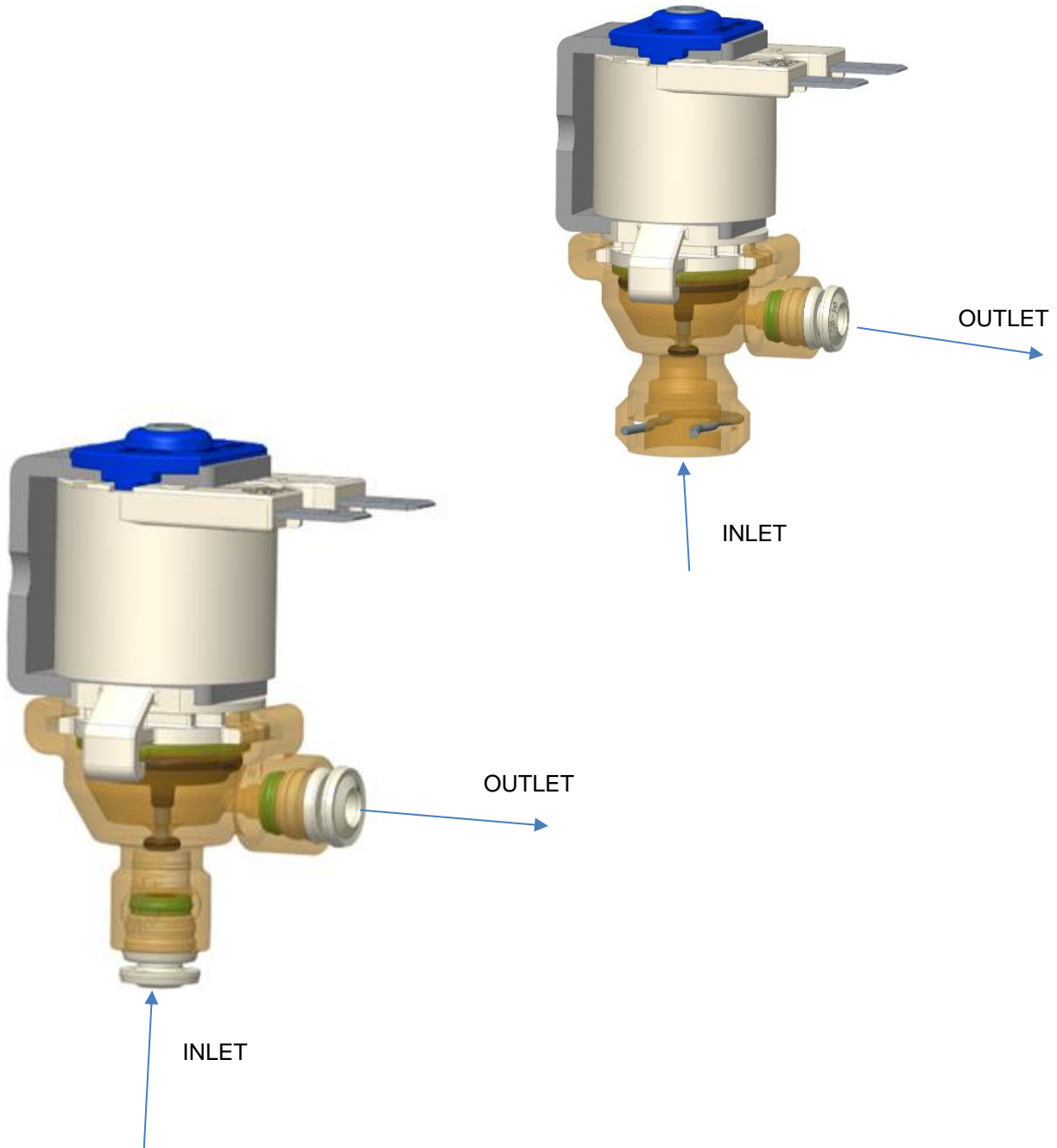



TECHNICAL DATASHEET *SCHEDA TECNICA*

Cod.: V2

FAMILY NAME: Steam Series V2 DN 1.5

Rev.: 01

FAMIGLIA: Serie Vapore V2 DN 1.5

Data: 24/11/2021

DIMENSIONAL DRAWING

DISEGNO DIMENSIONALE

Coupling Inlet - Outlet

Fork / Forchetta - Push Fit

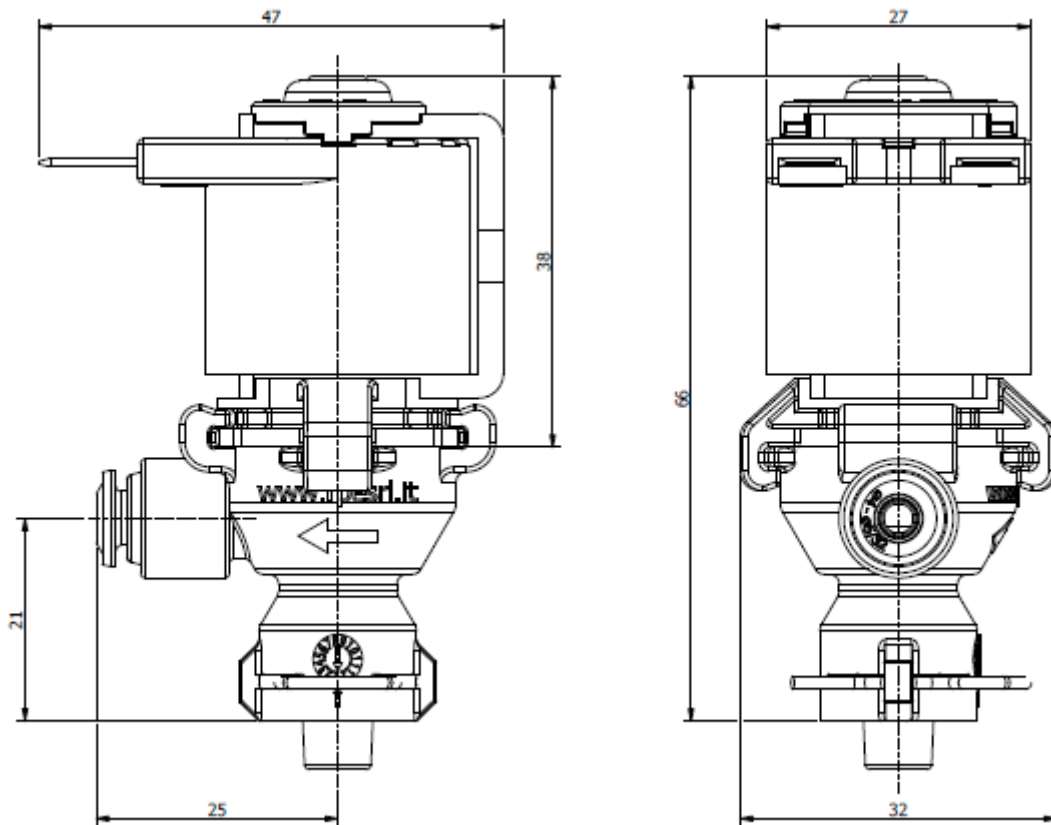



TECHNICAL DATASHEET *SCHEDA TECNICA*

FAMILY NAME: **Steam Series V2 DN 1.5**

FAMIGLIA: *Serie Vapore V2 DN 1.5*

Cod.: **V2**

Rev.: **01**

Data: **24/11/2021**

DIMENSIONAL DRAWING

DISEGNO DIMENSIONALE

Coupling Inlet -Outlet

Push Fit – Push Fit

